

# REDWOOD CANOE

...a beauty  
you can build

By FLOYD McGUICKIN  
and JACK PAYNE

**Y**ou can build this 74-pound, 16-foot canoe for \$84. For a new canoe, that's a real bargain. You use redwood strips, an old boat-building technique, a lie-flat blueprint you'll find on the following pages. The





**1** Make the building form and attach templates to the crosspieces. Nail a strip down the center to hold the stems and templates in position.

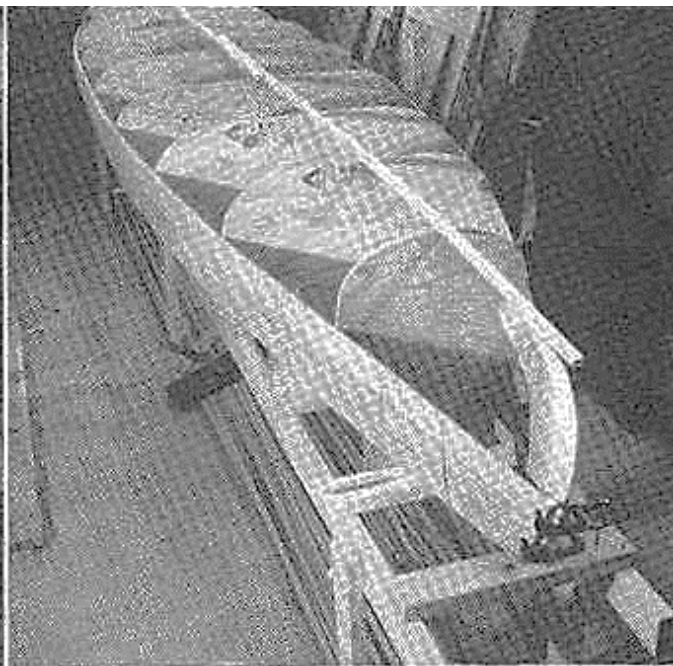

**2** Redwood strips are tacked to the templates, and edge-glued. Drive brads through into the templates before putting on fiberglass cloth.

prototype canoe took about three weekends to build. She's broad of beam and flat-bottomed amidship. Two persons can sit side by side in the center, with one person at each end and plenty of room for gear.

This canoe is formed around plywood templates using  $\frac{3}{4}$ "-by- $\frac{3}{4}$ " redwood strips, glued edge to edge. You lay up the strips, remove the form, and the canoe is complete, except for fiberglassing and putting in the seats.

**How to start.** First, lay out the patterns full size on large sheets of heavy brown wrapping paper. Since a canoe is symmetrical front to back and side to side, you need draw full-scale patterns of only half of each template, forming half of the canoe. The patterns are flopped to draw the other half of each template; duplicate templates are made from these for the other half of the canoe. Draw the template patterns using a  $\frac{1}{8}$ " grid as shown in the blueprint.

Build the form from four two-by-fours. Make it square, solid, and level; the finished canoe will be no better than the form it's made on. If built as shown, it can be converted into a bench for working on the canoe right side up.

Cut the templates from  $\frac{3}{4}$ " plywood and screw them to the building form. Make sure they are centered and vertical. Put on templates 1 and 9 first; then stretch a string over the center of these between the ends. This lets you line up the other templates. Next, make the canoe's stempieces

and set them in place on the frame. Glue two pieces of white pine together for each stem, and trace the lines from the full-size drawing on each. Bevel each piece to accept the redwood side strips. Tie together the stempieces and the templates with a  $\frac{1}{2}$ "-square strip of wood.

Next, rip the longer straight-grain redwood planks (see Materials List) into strips  $\frac{1}{2}$ " wide. You need about 70 of these strips to make the canoe hull.

Before planking the hull, put masking tape along the edge of each template to keep glue from sticking to it. Start planking at the gunwales, using  $\frac{1}{8}$ " No. 18 brads to

**5** Reinforcing strips are put on each stem after the hull gets its first coat of resin. Hull is then covered with two layers of glass and resin.

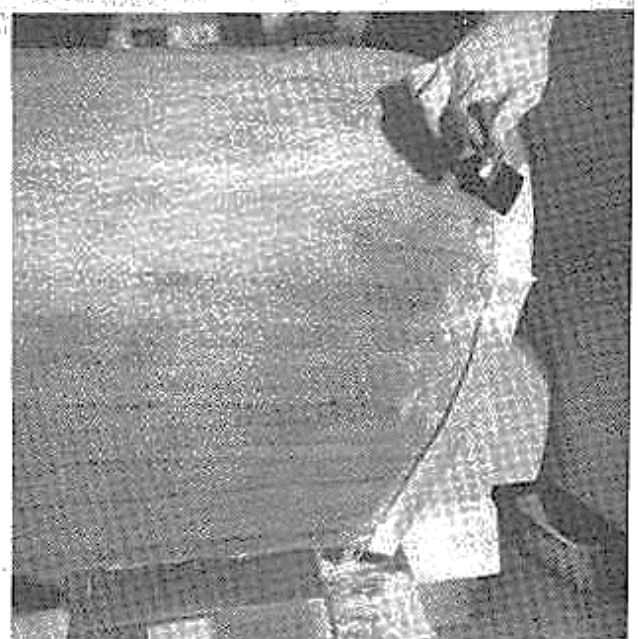



**3** Bevel strips so they meet in front of stem. A tight fit is not necessary, since the stems are covered with two layers of cloth and resin.

nail each strip to the templates. Place the strips so that the  $\frac{1}{2}$ " width forms the thickness of the hull. Don't nail the strips to the endpieces yet.

After each strip is nailed in place, put Elmer's Glue-All along its edge. As you lay each strip in place, hold it firmly against the strip below and nail it to each plywood template.

Do this until you have three or four strips on each side in place. Then cut each strip off  $\frac{1}{2}$ " beyond the stempieces. With a sharp knife, cut the inside of the strips to an angle that lets them meet in a point

*[See lie-flat blueprint on the following two pages. Text continued on page 200]*

**6** Hull is placed in tilted position on the building form for easy working on inside. Only one layer of cloth and resin is needed on inside.

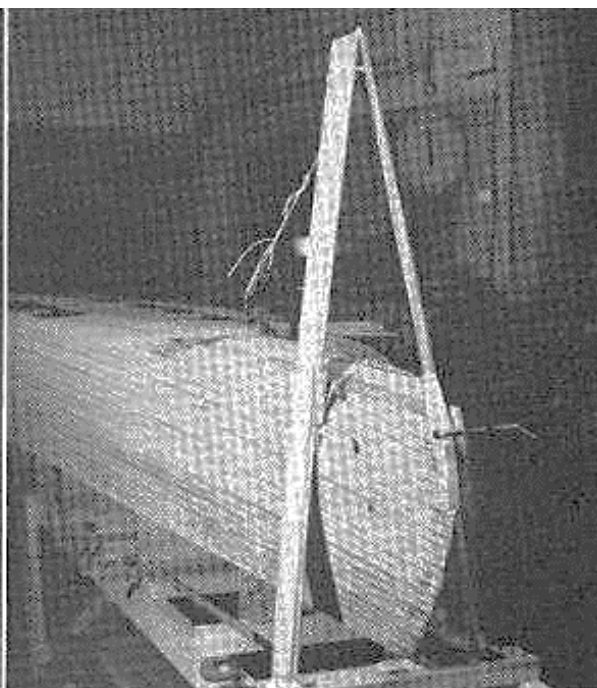
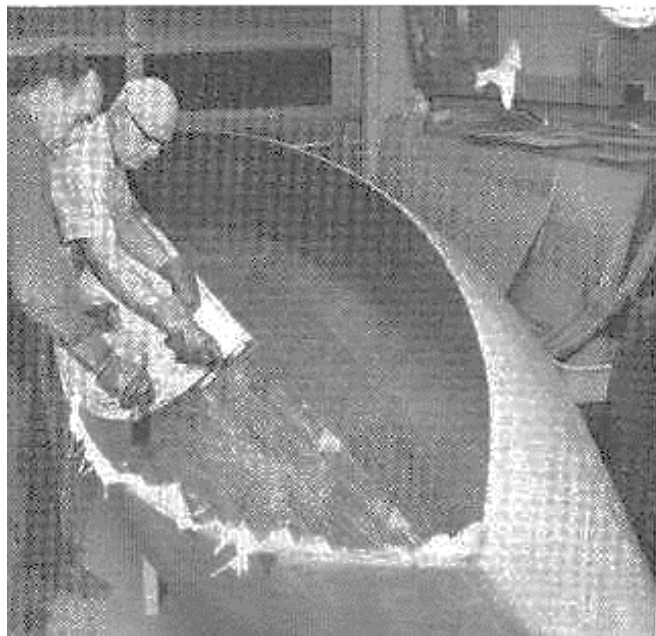

**4** Clamping jigs hold the strips in place when you reach the point where twist gets bad. Scraps from the beveled stem make good clamping pads.

beyond the stempieces. Glue them with resorcinol and nail them with  $\frac{3}{8}$ " copper nails.

A little ingenuity is needed to clamp the ends of the strips tight. A large rubber band (cut from an old inner tube) tightened with a stick through one end does a good job.

When you have added about 19 strips on each side, the twist at each end gets pretty bad. Clamps, shown in photos, hold them.

When about 25 are on, the strips meet along the keel. Cut them to meet in a staggered line along the keel.

**7** Finishing touches include adding gunwales, inwales, seats, yoke, and breast plates. You weave seats with webbing as shown in blueprint.

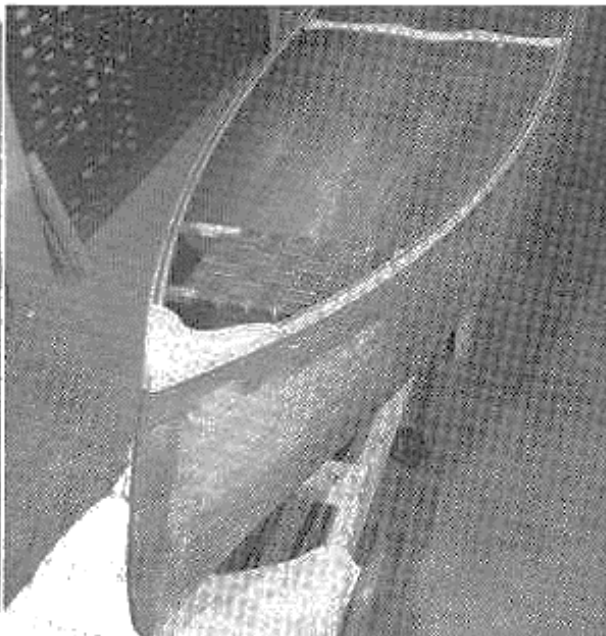

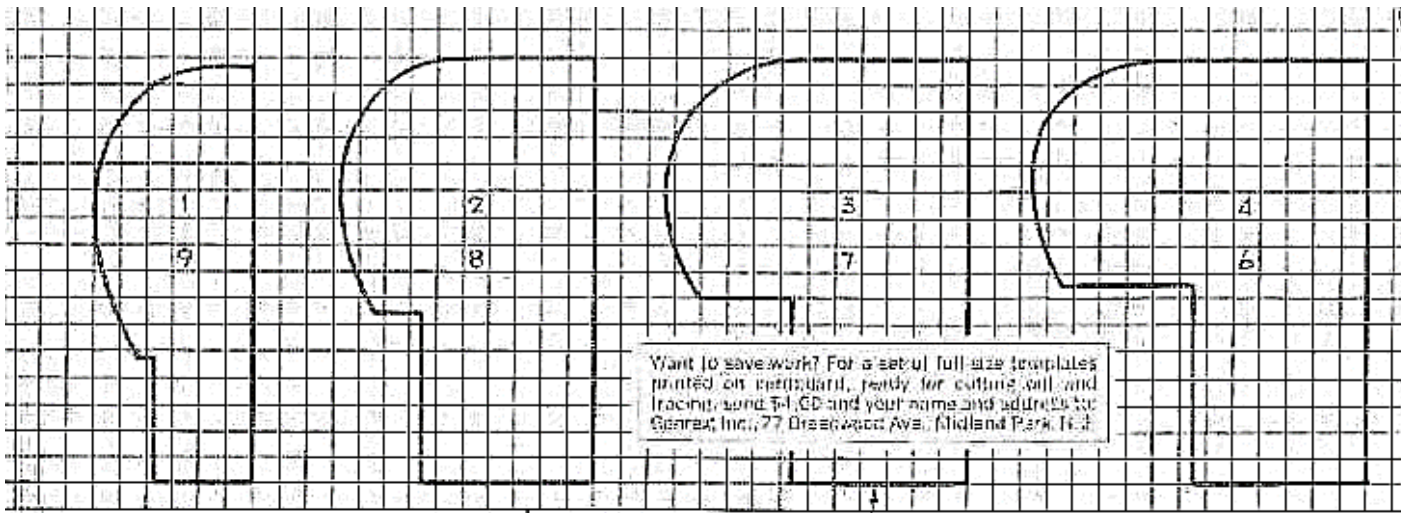

Want to save work? For a set of full size templates printed on cardstock, ready for cutting out and tracing, send \$1.00 and your name and address to: Genart, Inc., 77 Greenwood Ave., Midland Park, N.J.

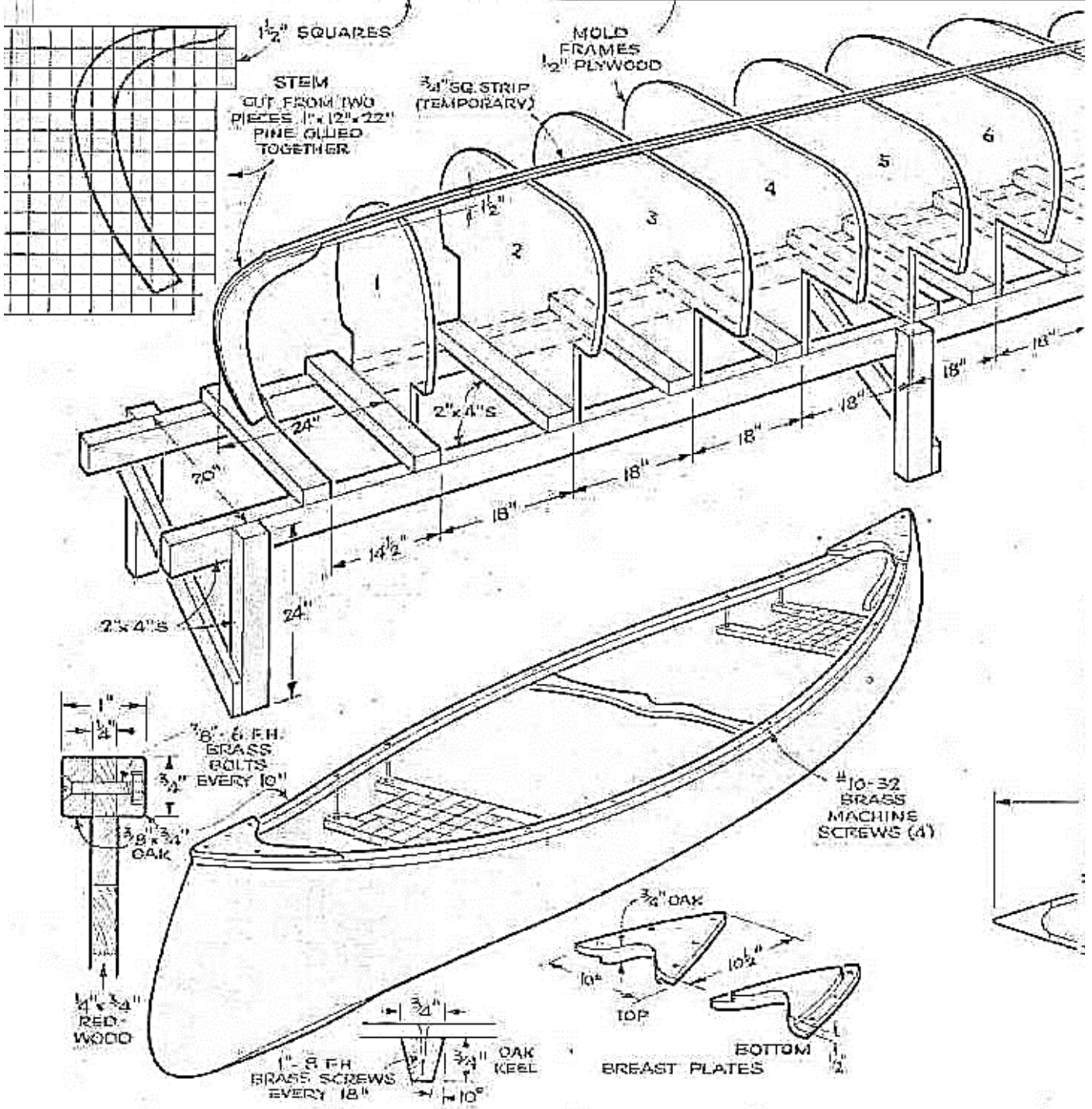

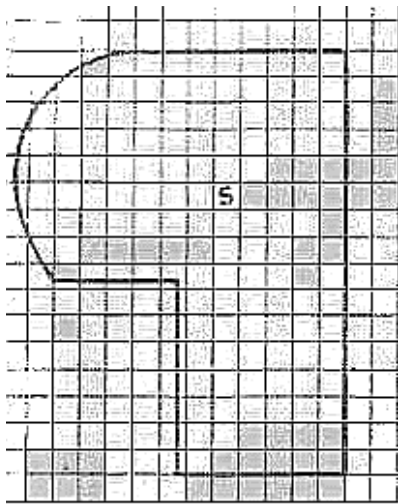

# REDWOOD CANOE

CHANGE FORM TO BENCH FOR WORKING INSIDE CANOE

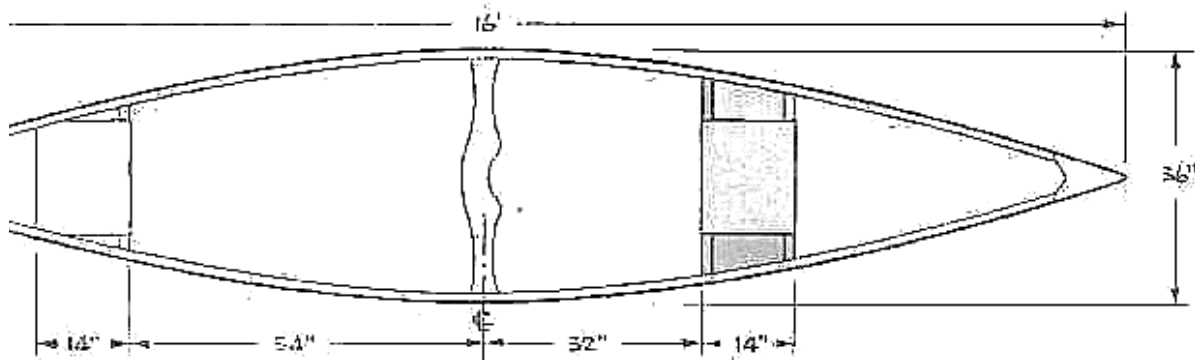
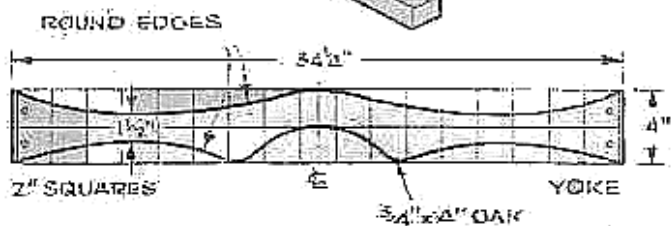
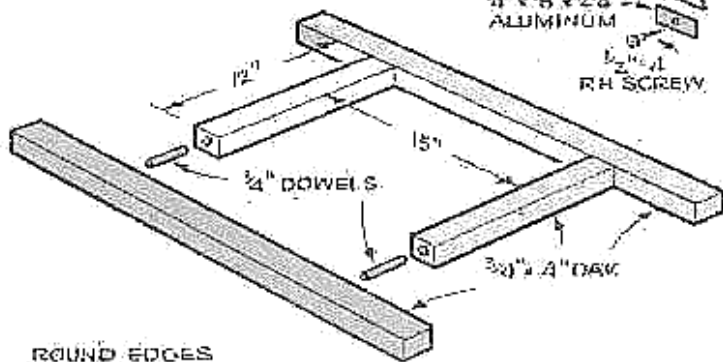
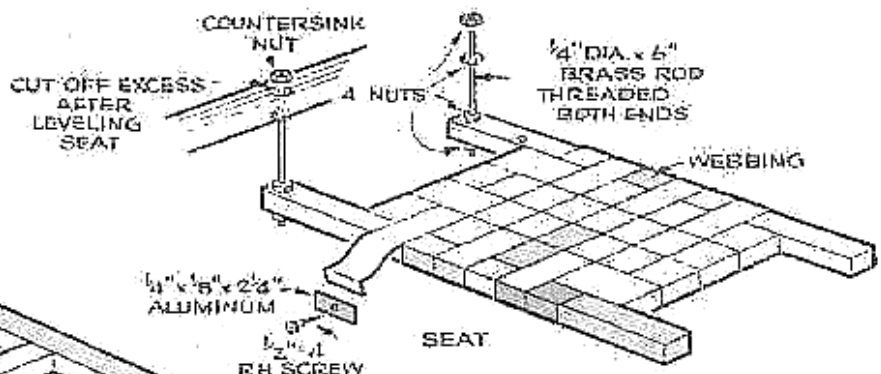
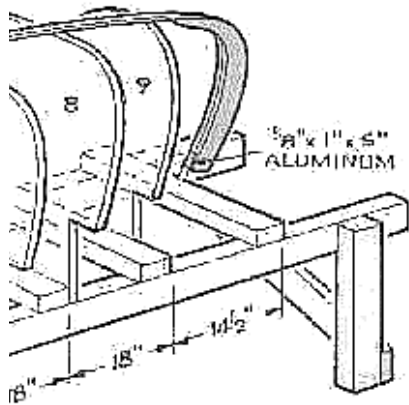
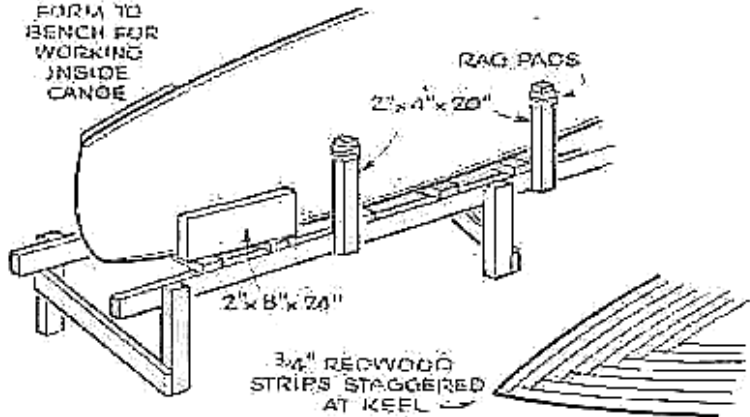

- MATERIALS**
- 4 pieces 2" x 4" x 16' straight-grain fir
  - 1 panel 4' x 8' x 1/2" fir plywood
  - 1 panel 4' x 4' x 1/2" fir plywood
  - 2 pieces 1" x 12" x 17' or 18' straight-grain redwood (cut in 1/4" strips)
  - 1 piece 1" x 6" x 14' straight-grain redwood (cut in 1/4" strips)
  - 3 pieces 1" x 12" x 7' clear white pine
  - 3 pieces 1" x 4" x 15' oak
  - 1 piece 1" x 4" x 2' oak
  - 1 piece 1" x 10" x 2' oak
  - 3 gallons polyester or epoxy resin
  - 11 yards 7/8" ounce, 60" wide glass cloth
  - 16-ounce bottle quick-setting glue (Eternal Glue All)
  - 1 pint waterproof glue (Durobond)
  - 15 yards webbing for seats
  - Nuts, screws, sandpaper

When all strips are in place, sand the hull and give the outside a coat of polyester or epoxy resin. When this has set, make a thin-point nail set and punch all nails in each strip through, into the form.

Cover the outside with glass cloth and another coat of resin. Start at the center and work the cloth toward each end. A few staples hold it while you apply the resin.

Use inexpensive paintbrushes to apply the resin. Wear rubber gloves, and use a squeegee to work the resin through fiberglass. After the first coat of resin, fit an extra strip of fiberglass at each end to overlap about 2" on each side.

When the resin is set, sand the rough spots and apply the second coat. Two coats of cloth and resin should be enough.

**Removing the templates.** After the outside is finished, take out the screws that hold the templates to the form, and carefully remove the templates. To do this, push them toward the larger part of the hull. Turn the canoe right side up on the building form to work on the inside.

Sand the inside and coat it with resin. Shape and attach the keel before glassing

and finishing the interior. The blueprint shows how to change the building form to hold the canoe at an angle; it makes working inside easier.

Cover only half of the inside at a time. This lets you overlap the glass at the center for more strength. Before putting in the full-length glass cloth, work some left-over pieces in at the stems.

You can cut 60"-wide cloth in half and staple the selvage about  $\frac{3}{8}$ " over the center line so that the keel screws are covered. Work it up the sides and toward each end. A few staples may be needed along the top edge until the resin is on; they may then be pulled out. One layer of resin and cloth is enough inside.

When the resin is set, trim off the excess glass cloth. Attach the gunwales and inwales with either screws or bolts.

Build and varnish the seats, breast plates, and yoke, and fasten them in place.

These plans let you build a 13' canoe, too. You build it the same way, but you eliminate templates 4 and 5, making template 6 the center of the hull. Nothing else need be changed. E 5

